



Service Bulletin

SB-0046

Rev_P1

PRODUCTS AFFECTED: ZT-2800®, ZT3100®, ZT3200®, and ZT3400®.

SUBJECT: Outboard Oil Retention Kit

Models NOT covered by kit #72828: ZJ-KMEB-5DLC-3DXX, ZJ-GMEB-5LDB-2DXX, ZM-KEEB-5LLG-3MLX, ZM-GEEB-5LLF-2MLX, ZM-KPEB-5LLG-3MRX, ZM-GPEB-5LLF-2MRX, ZM-KREB-5LLG-3MRX, ZM-GREB-5LLF-2MRX, ZU-KEEB-5LDC-3UXX, ZU-GEEB-5LDB-2UXX, ZU-KKEB-5LLG-3JRX, ZU-GKEB-5LLF-2JRX.

EFFECTIVE DATE: March 14, 2017

SERIAL NUMBER RANGE: All

DESCRIPTION: With the exception of models listed above, the outboard oil retention kit #72828 contains the parts necessary to eliminate leaking at the brake shaft for all other models in the product groups ZT-2800®, ZT3100®, ZT3200®, and ZT3400®. A kit will be provided at a later date for those models not covered as listed above.

The kit will supply a brake bore plug that is to be seated into the housing over the brake shaft on the outboard side, (see figure 1).

An o-ring, brake shaft spacer, and compression spring are provided and are to be installed on the inboard side of the brake shaft between the brake actuator arm and the inboard housing to provide a compression seal, (see figure 2).

* Reference the instruction sheet, SB-0048_P1, supplied with the kit for installation procedures.

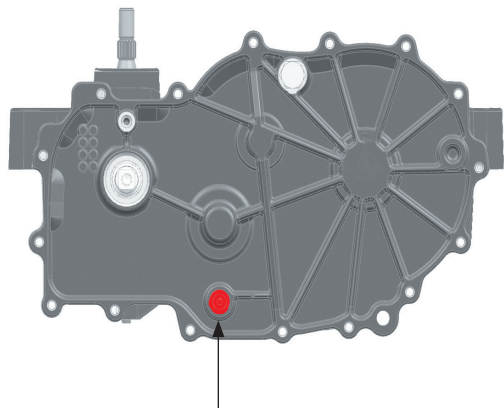

Brake bore plug placement

Figure 1

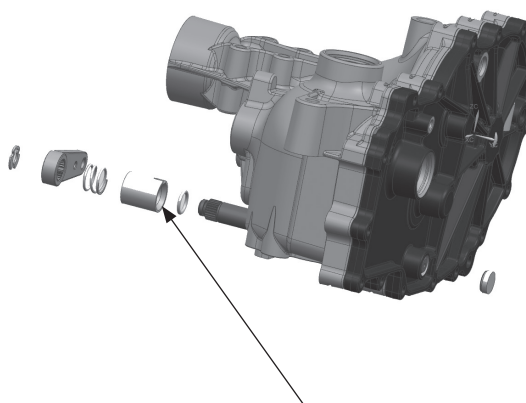

O-ring, brake shaft spacer, and compression spring placement

Figure 2