

# **ForkliftCertification.com**

## **Certification Class 1**

Phone: 888-278-8896

Email: [sales@certifyme.net](mailto:sales@certifyme.net)



# **ForkliftCertification.com**

## **Certification Class 1**

### **Topic 1/7: The Basics**



# The Basics

## Topic 1/7

### **What is a lift truck?**

Forklift trucks are a part of a family of work vehicles known as Powered Industrial Trucks. There are many different kinds of forklifts. Some of the more common ones are four wheel sit downs powered by any of the following: gasoline, LP gas, diesel, or electricity. Because the load is carried in front of the truck they are counter balanced by the weight of the truck itself, including the counter weight in the rear. Among the other lift trucks are the Stand Up Rider and the Walkie Rider Pallet Truck or Walkie. This training will cover class 1, 4, & 5 lift trucks you use in your workplace.

Any use of a lift truck for a purpose other than what it was designed for is unsafe. Unsafe use dramatically increases the chances of damaging goods or property or in a worst case scenario, causing loss of life. This training will stress proper operation of lift trucks by following the safety guidelines and gaining a comprehensive understanding of how they work.

A lift truck is designed to lift and carry. Lift trucks are NOT designed to push or pull loads. The use of a forklift for pushing or pulling can cause serious damage. Proper use of the lift truck will improve overall safety and extend the life of the truck.



**Class 1**  
**Electric Motor Rider Trucks**

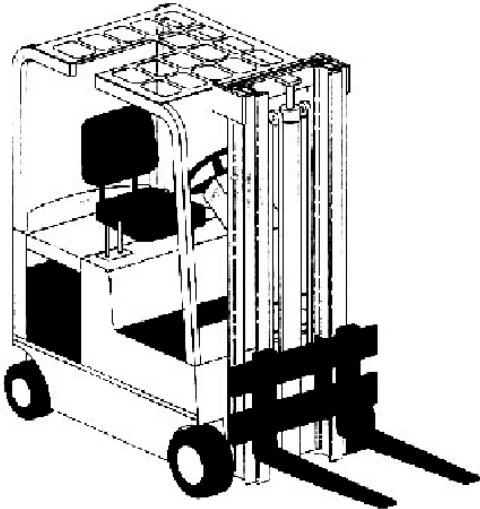

**Class 2**  
**Electric Motor Narrow Aisle Trucks**

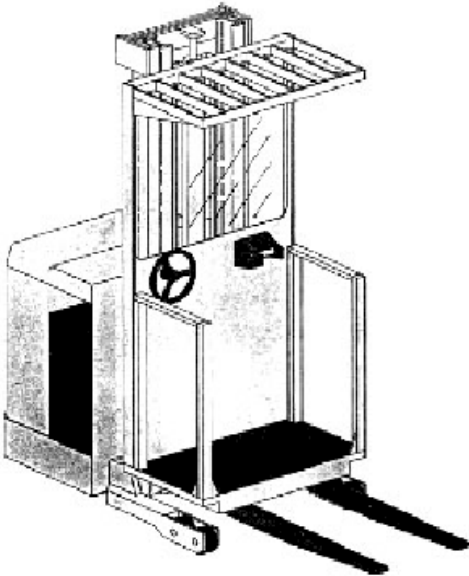

**Class 3**  
**Electric Motor Hand Trucks or Hand/Rider Trucks**

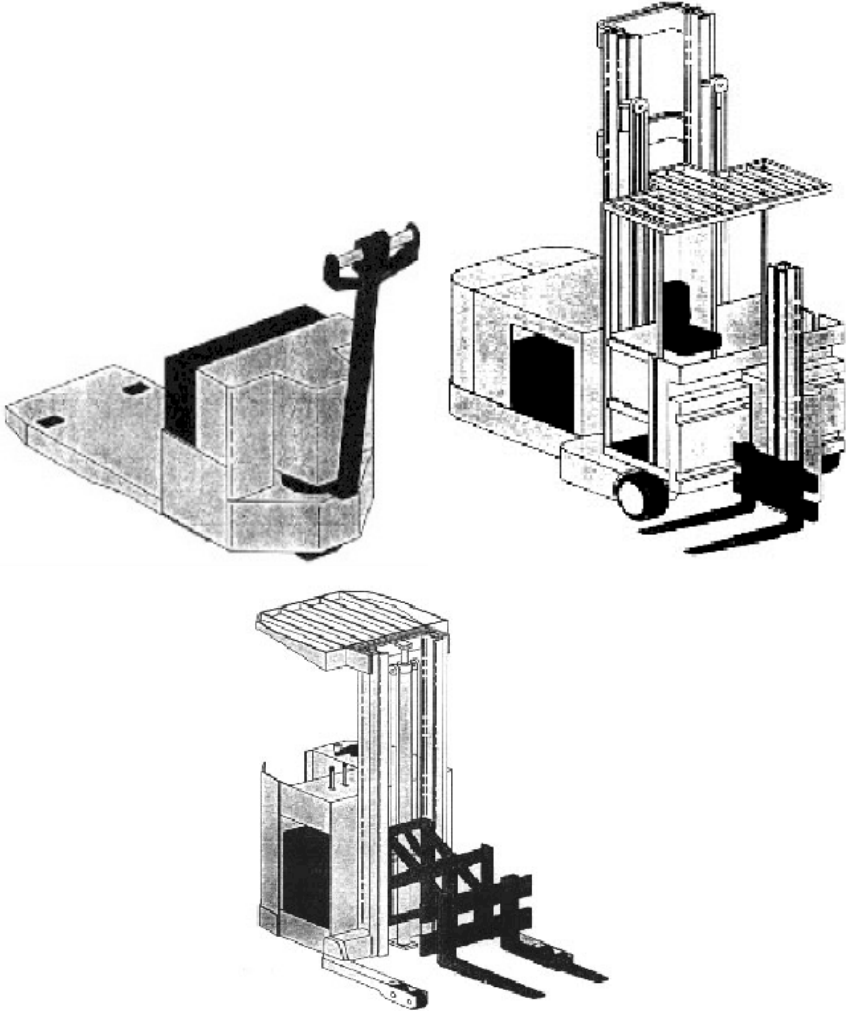

**Class 4**  
**Internal Combustion Engine Trucks Solid/Cushion Tires**

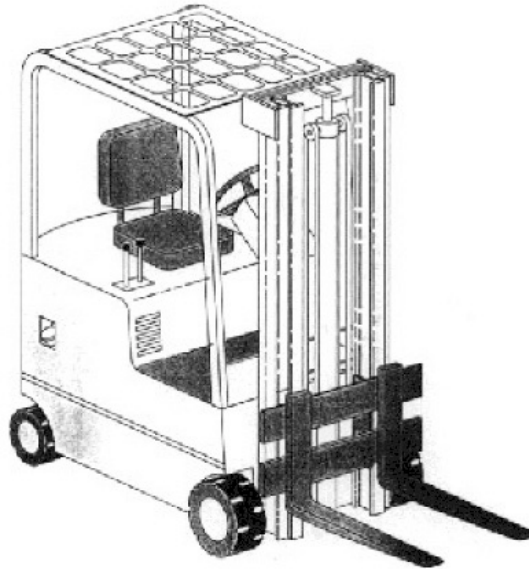

**Class 5**  
**Internal Combustion Engine Trucks Air/Pneumatic Tires**

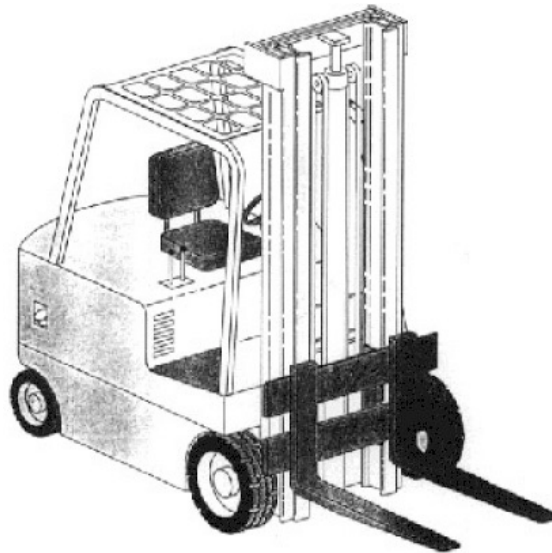

**Class 7**  
**Rough Terrain Forklifts**

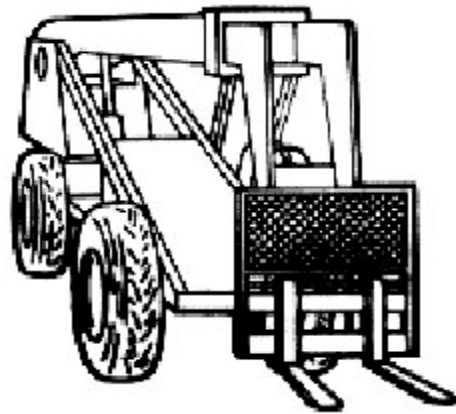

Always use the lift truck that's right for the job. A cushioned four wheel sit down truck is best suited to loading docks and open areas. A stand up reach truck has a tighter turning radius that best suits it for use in narrow aisles. The pneumatic tire truck is best suited for outside uses on rough or uneven terrain.

Lift trucks are different than automobiles. Lift trucks are designed for very different uses than automobiles and have few things in common. As a result, the training needed to operate an automobile is not enough when it comes to using a lift truck. Specific training and instruction is needed for different trucks and different jobs. Some lift trucks may have special attachments for use on certain jobs, such as: roll clamps, carton clamps, side shifters, and slip sheets. Besides knowing how to operate a lift truck the operator will have to be trained to operate any attachments as well.





# Certification Class 1

## Topic 1 of 7: Basics

### QUIZ

**1. Do the same rules for driving an automobile apply to lift trucks?**

- a) Yes
- b) No

**2. Who is responsible for preventing accidents?**

- a) Safety Officer
- b) Supervisor
- c) You
- d) Everyone



# Certification Class 1

## Topic: 1 of 7: Basics

### QUIZ ANSWER KEY

2. Do the same rules for driving an automobile apply to lift trucks?

a) Yes

b) No

2. Who is responsible for preventing accidents?

a) Safety Officer

b) Supervisor

c) You

d) Everyone



**ForkliftCertification.com**  
**Certification Class 1**  
**Topic 2/7: Inspection & Maintenance**



# Inspection & Maintenance

## Topic 2/7

A pre-operation inspection is now required under OSHA guidelines. When performed on a daily basis these checks will improve safety and increase productivity.

Before the start of each work shift, the operator must perform a daily inspection on the lift truck. The daily inspection is a two part checking routine: a visual inspection, and an operating inspection. Following the daily inspection any routine maintenance may be performed.

During the visual examination the items to be inspected include:

### Warning Decals/Operator Manual

- \_ Are all the proper decals on the truck?
- \_ Is the operator's manual on the truck?

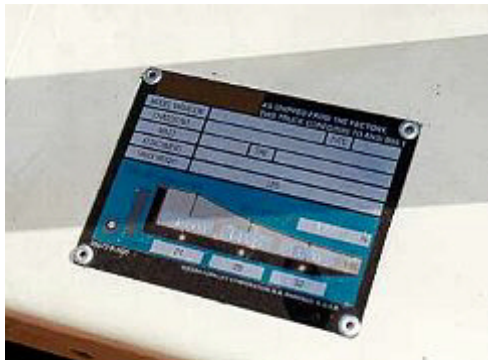

*Data Plate/Load Chart*

### Data Plate/Load Chart

- \_ Is the data plate in place on the truck?
- \_ If the truck has been modified, is the data plate current?



- \_ Is the data plate damaged or unreadable?

### Covers and Sheet Metal

- \_ Are any covers or sheet metal missing, cracked, broken, deformed?
- \_ Are latching devices working properly?

### Overhead Guard and Legs



- \_ Is the overhead guard or its legs bent or cracked?
- \_ Are all the fasteners secure?

### Tires and wheels

- \_ Are large pieces of tire missing?
- \_ Are lug bolts missing or loose?
- \_ Are wheel hubs damaged?
- \_ Are tires inflated properly?



### Fluid Levels & Lubrication

- \_ Are all fluids at the proper level
- \_ Has lubrication been applied on schedule?

### Drive Axle

- \_ Is the axle leaking?



### Forks

- \_ Are the forks bent, cracked or worn?
- \_ Are the fork stops in place?
- \_ Do the fork locks work correctly?



### Load Back Rest

- \_ Is the load back rest twisted, bent, or cracked?
- \_ Are the mounting bolts secure?

### Hydraulic Oil

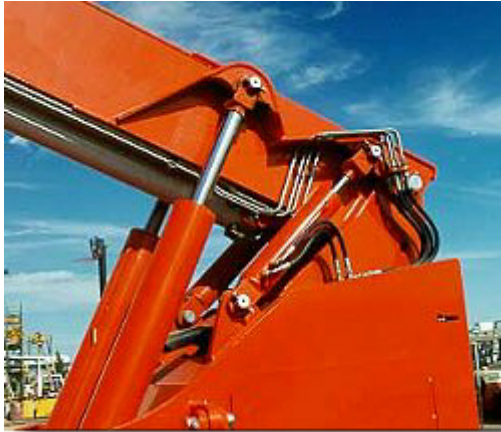

- \_ Is the oil filled to the proper level?
- \_ Is the oil clean and clear?
- \_ Are there any visible leaks?
- \_ Are there any drips beneath the truck?



## Engine Oil



- \_ Is the oil filled to the proper level?
- \_ Are there any visible leaks?
- \_ Are there any drips beneath the truck?

## Cooling System

- \_ Is the radiator filled to the proper level?
- \_ Are there any leaks from hoses water pump, radiator, engine?
- \_ Are there any puddles beneath the truck?
- \_ Are hose clamps and fan belts tight?
- \_ Is the fan belt worn or cracked?





## Battery, Connectors, and Hold Down

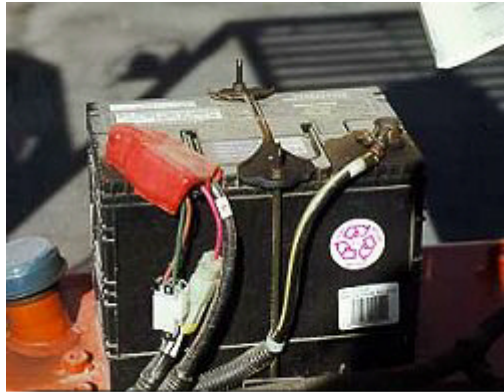

- \_ Are the connectors tight and free of corrosion?
- \_ Is the battery electrolyte at the proper level?
- \_ Is the hold down secure?

**During the operating inspection the following will be evaluated:**

### Seat

- \_ Is the frame cracked?
- \_ Are the cushions properly attached to the frame?

### Operator Restraint System

- \_ Is there an operator restraint system in place and does it function properly?
- \_ Is the seat belt or harness worn?
- \_ Does the latching device lock and unlock properly?
- \_ If the truck has a tether does it operate properly?
- \_ Is the tether frayed or cracked?





### Horn

- \_ Does the horn function properly?

### Gauges/Instruments

- \_ Do all the gauges work?
- \_ Are any of the gauge lenses cracked or clouded?
- \_ Do all indicator lights illuminate when the key switch is in the on position?

### Battery Test (Electric Trucks)

- \_ Does the indicator show full charge after the battery is replaced?

### Accelerator

- \_ Does the accelerator operate smoothly?

### Control Levers

- \_ Do the levers move smoothly?
- \_ Does each function activate properly when the control lever is operated?
- \_ Do the levers return to their centered position properly?





### Directional Controls

- \_ Do the directional controls move smoothly?
- \_ Does the direction become active when selected and does the truck move in that direction?
- \_ Does the control return to its centered position properly?

### Drive Axle

- \_ Are there any unusual noises coming from the axle when the truck is moving?

### Steering

- \_ Does the steering wheel and steer axle turn smoothly lock to lock?
- \_ Does the steering bind?
- \_ Are there any unusual noises while steering?



### Head/Tail/Running Lights

- \_ Do all lights illuminate when turned on?
- \_ Are any bulbs dim or burned out?

### Warning Lights

- \_ Do all warning lights illuminate properly?

### Backup Alarm

- \_ Does the alarm sound when the truck is put in reverse?

### Brakes

- \_ Is the brake pedal high and firm when applied?
- \_ When pressure is applied for a ten second period does the pedal slowly sink down?

### Service Brake

- \_ Does the service brake hold the truck in place when applied?
- \_ Is it set to the manufacturers specifications?

### Parking Brake

- \_ Does the parking brake hold the truck in place when applied?
- \_ Is it set to the manufacturers specifications?

### Seat Brake

- \_ Does the seat brake hold the truck in place when applied?
- \_ Is it adjusted properly?



## Mast

- \_ Does the mast move up and down smoothly?
- \_ Is there any visual damage to the channels?
- \_ Are any of the rollers cracked or non-moving?
- \_ Does the mast sink back down?
- \_ Are there any frayed or cracked hoses?
- \_ Is there any hydraulic oil leaking anywhere?

## Tilt

- \_ Does the mast tilt back and forth smoothly?
- \_ Does the mast drift forward or backward?
- \_ Are any cylinders leaking?
- \_ Are all retainer pins in place?

## Carriage and Attachments



- \_ Are the carriage bars bent?
- \_ Are the notches on the top of the carriage worn?
- \_ Do the forks lock in place?
- \_ Is the carriage loose in the channels?
- \_ Does the carriage lean as it goes up or down?
- \_ Are any rollers missing?
- \_ Do the rollers all move smoothly inside the mast channels?
- \_ Are the chains attached properly?
- \_ Are the chains lubricated?
- \_ Are the chains rusty?
- \_ Is the chain tension even?
- \_ Is there excessive play in the chain when it is lowered?
- \_ Does the attachment perform properly?
- \_ Is the attachment mounted securely to the carriage?
- \_ Is the attachment damaged?

Your employer will have a checklist with descriptions of the items that must be inspected and tested before using the truck. If at any time a lift truck is found to be defective, in need of repair, or unsafe the truck must be taken out of service. Your supervisor should be notified immediately and made aware of which items failed inspection. Once the problems have been corrected and the truck has been restored to a safe condition it can be put back to work. Inspecting all of these items on a daily basis will help keep the truck in the safest operating condition possible.



# Certification Class 1, Topic: 2 of 7: Inspection & Maintenance

## QUIZ

**3. When should a lift truck be taken out of service if it is found to be in need of repair during a pre-operation inspection?**

- a) At the end of the work shift
- b) First thing in the morning
- c) Immediately

**2. Are hoses with leaks serious enough to put a lift truck out of service?**

- a) Yes
- b) No



# Certification Class 1

## Topic: 2 of 7: Inspection & Maintenance

### QUIZ ANSWER KEY

4. When should a lift truck be taken out of service if it is found to be in need of repair during a pre-operation inspection?

- a) At the end of the work shift
- b) First thing in the morning
- c) Immediately

2. Are hoses with leaks serious enough to put a lift truck out of service?

- a) Yes
- b) No





**ForkliftCertification.com**  
**Certification Class 1**  
**Topic 3/7: Safe Operation**



Certification Class 1  
Topic: 3 of 7: Safe Operation

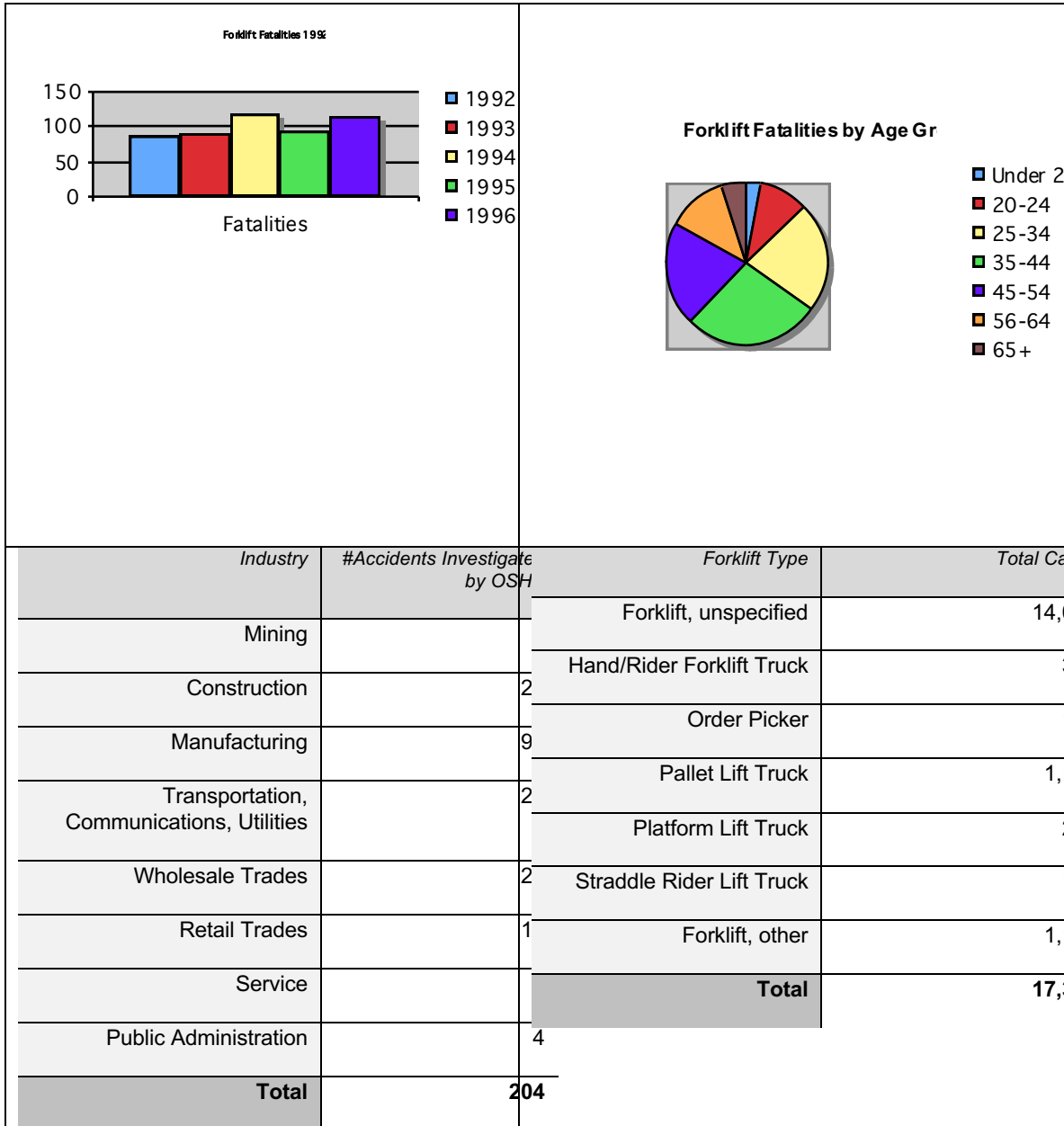

Before driving any lift truck, you must read the operator's manual to become familiar with the particular truck you will be using. Lift truck operators are expected to observe and follow all warning decals posted on the vehicle.

### **Starting the lift truck**

For safety reasons only enter or exit a lift truck when the parking brake is applied. Never jump on or off a moving lift truck. With most lift trucks you step up and into the operator compartment using available handrails and steps for assistance. Once you are seated adjust the seat so all controls are easily reachable and fasten the seat belt. Set the directional controls to neutral, apply the brake and disengage the clutch. Start the engine. Make sure that your entire body, including hands and feet stay within the operator compartment at all times. Do not put any part of your body within the mast mechanism; reach mechanism, or any of the other attachments on the truck.

### **Stopping the Lift Truck**

Come to a complete stop with all controls in the neutral position before exiting a lift truck. Apply the parking brake and lower the forks completely before turning the truck off. Exit the truck back first using the appropriate hand and foot holds to steady yourself as you step down from the truck.

### **Proper Use**

Lift trucks should only be used for their intended purpose in designated areas. Make sure your lift truck is properly rated for the specific work area and the conditions of the job site. Both OSHA and the National Fire Protection Association have created specifications for lift trucks working in hazardous areas. These specifications include special safety features on the truck that reduce the risk of a fire or an explosion.

Operating an internal combustion engine lift truck in an enclosed area can be dangerous if that area is not well ventilated. Under certain conditions, you may be required to wear protective equipment that is appropriately rated for the environment you're working in.



Lift trucks are often used in warehouses or areas with rows and intersecting aisles. This creates traffic patterns. Because of this an operator must stay alert due to the high density of people and equipment being moved in the vicinity.

**General Lift Truck Operation Rules:**

- \_ Observe all safety rules and traffic regulations, including those posted by the company or facility.
- \_ Follow established company policies for operating in traffic patterns. Stay within the designated lanes or aisles.
- \_ Keep to the right unless instructed otherwise.
- \_ Travel with the load tilted back and the forks in lowest position allowed by the driving surface or terrain.
- \_ Maintain a clear view of the path of travel observing other traffic, pedestrians, and obstacles.
- \_ Yield the right of way to pedestrians.
- \_ Never give rides to pedestrians.
- \_ Slow down and sound horn or warning device at intersections, blind spots, or other dangerous locations. Check convex mirrors posted at corners.
- \_ Slow the truck to a safe speed when turning.
- \_ Make starts, stops, turns or directional changes in a smooth manner to avoid a load shift that could lead to an overturned truck.
- \_ Keep the truck under control at all times.
- \_ Slow down and proceed cautiously on wet and slippery surfaces.
- \_ Never drive recklessly.
- \_ Avoid running over loose objects



- \_ Maintain a safe distance of at least 3 truck lengths when following another vehicle.
- \_ Never pass another truck traveling in the same direction.
- \_ Always use the operator restraint system when in the vehicle.
- \_ Never assume that pedestrians are aware of you. If you need to pass a pedestrian, sound your horn and make eye contact.

Because the turning radius on a lift truck is so tight the operator must be aware of the arcing motion of the rear end swing. In tight turns, the rear end swings out and around the outside of the drive wheel path. If an operator is negligent, rear end swing can result in damage or injury. If an accident should occur resulting in either, injury to personnel, damage to a building structure, product or equipment, the operator must contact a supervisor or safety officer immediately.

The areas you will be operating your truck in as well as the surfaces you operate on vary. Often the surfaces will not be smooth or continuous. Reduce speed on slick or uneven surfaces and never run over loose objects or through holes.

Being able to recognize and avoid hazardous conditions that could cause injury or damage is only half of your responsibility. Hazards should be removed whenever possible. If not, then the area should be marked with a caution marker or tape and reported to a supervisor.

Downhill and uphill grades such as a ramp require extra caution. If traveling empty, regardless of direction, always drive with the truck's forks pointing down the grade. When moving a load, regardless of direction, always move with the forks pointing up the grade.

Uneven surfaces like railroad tracks should be approached slowly, at an angle while keeping a firm hold on the steering wheel. Working on surfaces requires skill and a high regard for the rules of safe operation.

When working on an elevated surface, such as a dock or pier, maintain a safe distance from the edge during all maneuvers.



## Trailers and Rail Cars

Before entering any trailer with a lift truck make sure that the trailer or rail car can handle the additional weight. Knowing the weight of the truck and of the load is critical information. Before moving into a trailer or rail car check the following:

- \_ Make sure the trailer/rail car is secure against movement.
- \_ Set the brakes on the rail car.
- \_ The trailer should have its wheels chocked.
- \_ If not attached to the tractor, the trailer should use jack stands or other reliable means of support.

After making sure that the trailer is properly secured, check the dock plate to make sure it is secure and in place. Be sure to check the dock plates for wear and cracks. This is very important because the dock plate bridges the gap between the dock and the trailer.

Check the floor surface and its capacity rating. The combined weight of the lift truck and load must not exceed the capacity rating.

Once the trailer door is open, turn on any available lighting to clearly illuminate inside the trailer. The floor of the trailer should be thoroughly examined to see if there are any cracks, holes or excessive wear in the floor. Any debris on the floor should be cleared out of the way. Unstable loads should be rearranged so they can be picked up safely. Only after these initial checks have been completed should the lift truck enter the trailer and begin unloading.

When entering a trailer for the first time drive slowly and cautiously. Turn on the truck's headlights if it is equipped with any and sound the horn. The first time the lift truck enters a trailer you will feel the trailer lock against the chocks. If there is any doubt about how to make any of these safety checks, ask your supervisor to make them with you.



## Parking a Lift Truck

There are two ways of parking a lift truck, attended and unattended. A powered lift truck is considered attended when the operator is less than 25 feet away and the truck remains in view. The engine can be left running while the operator is off the truck, if:

1. The directional control is set to neutral.
2. The parking brake is set.
3. The forks are lowered completely and tilted slightly forward to keep the ends against the floor.

If the operator is over 25 feet from the truck or the truck is out of view it is considered unattended and must be parked and powered down. The unattended parking procedure is:

1. Set the directional control to neutral.
2. Park the truck in a designated area.
3. Lower the forks to the ground and set the parking brake.
4. Turn off the engine.
5. For an LP truck, turn the service valve on the LP bottle off.
6. Park on level surfaces if possible, otherwise chock the wheels.
7. Park the truck away from heat sources, aisles, stairways, pedestrian traffic, railroad tracks or fire and safety equipment.



# Certification Class 1

## Topic 3 of 7: Safe Operation

### QUIZ

**1. Is it necessary to set the brake if the operator is within 25' of an attended lift truck?**

- a) Yes
- b) No

**2. Who should be immediately notified if an accident occurs?**

- a) The supervisor.
- b) Any coworker.





# Certification Class 1, 4, 5

## Topic 3 of 7: Safe Operation

### QUIZ ANSWER KEY

1. Is it necessary to set the brake if the operator is within 25' of an attended lift truck?

a) Yes

b) No

2. Who should be immediately notified if an accident occurs?

a) The supervisor.

b) Any coworker.



**ForkliftCertification.com**  
**Certification Class 1**  
**Topic 4/7: Load Handling**



# Certification Classes 1

## Topic 4 of 7: Load Handling

Once the controls of the lift truck you are going to operate become familiar, you must familiarize yourself with the correct way to engage, pick up, carry, deposit, and disengage loads.

Before engaging any load check the weight of the load to make sure it does not exceed the capacity of the lift truck. The weight may be marked on the load itself or written in a bill of lading. Inspect each load prior to moving it.

### **If the load is loose, unbalanced or not secure:**

- \_ Reposition the load to balance it.
- \_ Move the items closer together to tighten up the load.
- \_ Strap the items together.

If the pallet that the load sits on is damaged, transfer the load onto a pallet in good condition prior to moving the load.

**Do not** move a load if you question the load's condition or weight.  
**Do not** move a load until it has been weighed and/or secured.

### **Picking up a Load**

Check the fork spacing after stabilizing the load and prior to engaging it. The best fork spacing is at least two-thirds the length of the load, adjusted for even spacing between pallet stringers and maximum width.

Before engaging, the truck needs to be squared with the load. Raise the forks so they're just clear of the pallet opening. Approach slowly until the load just touches the carriage. Be careful not to bump into the load being engaged.

Make sure that the load does not exceed the height of the backrest. Raise the load (4" - 6") enough to clear the surface it is resting on. Pay



close attention to the overhead clearance looking out for overhead obstructions. Do not pick up a load unless it is fully engaged. Tilt the mast back a bit to cradle the load. Check the sides of the load. Check behind the truck. Sound the horn and carefully back the truck out.

For extremely large loads rest extensions are available to help stabilize. The load should not exceed the height of the back rest extension.

With the load under control proceed to the destination to unload. Keeping the load as low as possible will help keep the truck stable and avoid overhead obstructions. It also provides the best viewing area as while transporting loads. If the forward view is obstructed by the load, drive in reverse. However, be careful not make an on-the-go change of direction when carrying a load.

Always move at a safe rate that allows for controlled maneuvers. Acceleration, turns, deceleration, and stops should all be smooth and carefully executed. When approaching a corner slow down, sound the horn, and stay near the inside corner.

- At corners the correct way to turn is to start turning when the inside drive wheel reaches the corner. Always sound the horn or use a spotter when approaching a ramp entrance while carrying a load.
- Caution should be exercised whenever encountering corners, dangerous surfaces, or ramps.
- Avoid raising a load while traveling. Raising the height of the load can drastically change the truck's stability.
- Never allow pedestrians or other traffic to move under a raised load.

### **Depositing a Load**

A load is deposited in the reverse order of picking it up. The inching pedal on some trucks allows the operator to creep the truck into position during extremely slow maneuvers. Also, by using the inching pedal, the engine speed is increased which creates an increase in lift speeds. However, riding the inching pedal for extended periods of time



causes overheating and premature failure of the transmission. Simple unloading consists of placing the load on the floor and disengaging. Move the load over the selected location. Tilt the mast to vertical and slowly lower the load to the floor. Check behind the truck, sound the horn and carefully back away to disengage the truck's forks.

If the load needs to be stacked, line up the truck squarely with the area where the load will be stacked. Tilt the mast forward so it is straight up and down. If the truck is equipped with a side shift it should now be adjusted right or left to center the load. Raise the load even with the stacking level. Slowly creep forward to locate the load over the unloading point while maintaining the correct stacking alignment. When the load is in position lower it, slowly and squarely, until the weight of the load is fully in contact with the stack below it. Check behind the truck, sound the horn, and slowly back away. When the forks are safely disengaged from the load, stop the truck and lower the forks 4 - 6 inches above the floor.

Be careful when lowering a load to avoid over-lowering the carriage to the point where there is slack in the chains. When the truck backs away from the load, the carriage will then drop causing extreme stress on the lift chains. If the load needs to be adjusted, pick it back up and reposition it. Do not shove it around with the truck forks.

**Tip-over is the number one cause of lift truck fatalities.**

A tip over can occur because of:

- \_ Overloading
- \_ Sharp turns
- \_ Abrupt braking
- \_ Excessive speed
- \_ Striking overhead obstructions
- \_ Driving over uneven surfaces
- \_ Driving on ramps incorrectly



All of these actions can cause a lift truck to tip over. Strictly following accepted guidelines and procedures is the best way to avoid tip over.

If you should become involved in a tip over, do not jump from the truck. The seat belt and framework around the operator's compartment are designed to protect the operator. **In a tip over situation:**

- \_ Remain seated with your seat belt fastened.
- \_ Hold onto the steering wheel.
- \_ Brace yourself and lean away from the fall.

Most fatalities occur when the operator is not wearing a seat belt or attempts to jump from truck.



# Certification Classes 1

## Topic 4 of 7: Load Handling

### QUIZ

**1. Is it necessary to chock the tires of a small trailer?**

- a) Yes
- b) No

**5. When depositing a load should the forks be lowered to the point that there is slack in the chains?**

- a) Yes
- b) No



# Certification Classes 1

## Topic 4 of 7: Load Handling

### QUIZ ANSWER KEY

1. Is it necessary to chock the tires of a small trailer?

a) Yes

b) No

6. When depositing a load should the forks be lowered to the point that there is slack in the chains?

a) Yes

b) No





**ForkliftCertification.com**  
**Certification Class 1**  
**Topic 5/7: Stability**



# Certification Class 1

## Topic 5 of 6: Stability

Operating an empty lift truck is completely different than operating a loaded truck. To operate a lift truck you must know the capacity limits and the effects of any load on the truck. Careful operation and a stable, balanced load keep a lift truck from tipping over.

### Lift Truck Load Capacity

Every forklift has a capacity plate located where an operator can read it. It is a federal regulation that the load chart be accurate and legible.

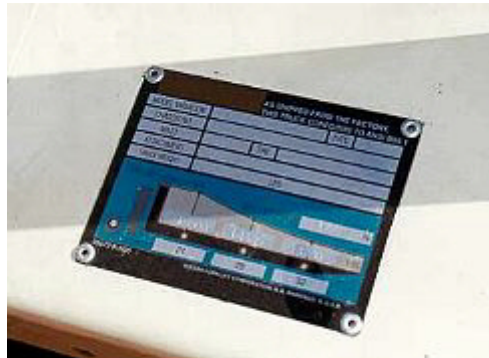

Check the load chart to see if the truck you're operating has the capacity to lift and carry a load. Be sure to engage the load properly with the forks in the correct position. Keep the load close to the floor when traveling and never raise or tilt the load while moving. It is essential that the truck and load be under control at all times.

Capacity ratings are usually based on a 24" load center, measured 24" from the face of the forks and 24" from the top of the forks. The center of this imaginary cube is the load center. When a load is moved outside of the 24" centerline there is a decrease in the amount of weight that can be handled safely. Refer to the load chart on the truck to determine the load capacity.



## Load Triangle and Center of Gravity

This is called the load triangle. The triangle is calculated from the center of the steer axle to both drive wheels. The center of gravity is represented by the dot in the triangle. Pictured is the center of gravity on an empty truck.

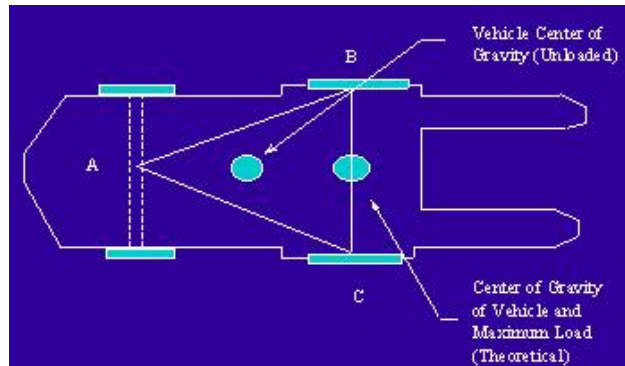

As the truck is loaded, the center of gravity shifts toward the drive axle. As long as the center of gravity remains within the triangle, the truck is stable. If the center of gravity moves outside the triangle, an unstable condition develops and the truck can tip over.

The two main causes of tip over are overloads and momentum. Strictly following the load chart, eliminates overloading as a problem. Momentum must be dealt with in a variety of ways to ensure that tip overs do not develop.

The position of the load, as well as the height off the floor of the forks, are very important.

Keeping the forks 4" - 6" off the floor while loaded is recommended. Even if the truck is not overloaded, in the raised position the load can cause the mast to act as a lever and the drive axle as a fulcrum, causing a tip over. This is why turns and sudden stops with a raised load and operating the mast while moving are so dangerous.

Momentum is an extremely powerful force that can easily tip lift trucks over. A tip over can occur in any direction, forward, backward, or to the side, depending which way the momentum is moving.



Any attachments cause the truck to act as if it is partially loaded. This reduces the amount of load that can safely be handled by the truck. Always consult the load chart of the truck being operated.



# Certification Classes 1

## Topic 5 of 7: Stability

### QUIZ

**1. When is a lift truck most stable?**

- a) Loaded
- b) Unloaded

**7. Is overloading as serious a problem as momentum?**

- a) Yes
- b) No



# Certification Classes 1

## Topic 5 of 7: Stability

### QUIZ ANSWER KEY

1. When is a lift truck most stable?

- a) Loaded
- b) Unloaded

8. Is overloading as serious a problem as momentum?

- a) Yes
- b) No



**ForkliftCertification.com**  
**Certification Class 1**  
**Topic 6/7: Fueling**



# Certification Class 1

## Topic 6 of 7: Fueling

Liquid propane, gasoline, and diesel are the most common fuels for internal combustion engine lift trucks. The best time to refuel the truck is at the beginning of a shift.

### Gasoline and Diesel Engines

Individuals who refuel lift trucks must be properly trained for the type of fuel and the truck. Refueling should take place in a well-ventilated area following set procedures and general safety rules.



- \_ Never refuel near sparking equipment or high heat sources.
- \_ Never smoke while refueling.
- \_ Know the location of the nearest fire safety equipment and how to use it.

Park the truck in the designated refueling area before gasoline or diesel refueling. Place the directional control in neutral and engage the parking brake. Lower the forks to the ground and angle the tips down. Turn the key switch to the "off" position before refueling. Do not add fuel to an overheated truck. Be sure to use the correct fuel for the truck. Fill the tank slowly avoiding overfilling. If any fuel is spilled, wash





down the area with water. If any leaks are detected in the fuel system, do not operate the truck until the problem has been corrected.

- \_ Park the truck in the designated refueling area before gasoline or diesel refueling.
- \_ Place the directional control in neutral and engage the parking brake.
- \_ Lower the forks to the ground and angle the tips down.
- \_ Turn the key switch to the "off" position before refueling.
- \_ Do not add fuel to an overheated truck.
- \_ Be sure to use the correct fuel for the truck.
- \_ Fill the tank slowly avoiding overfilling.
- \_ If any fuel is spilled, wash down the area with water.
- \_ If any leaks are detected in the fuel system, do not operate the truck until the problem has been corrected.

### **Liquefied Petroleum Gas Engines**

In the lift truck industry, Liquefied Petroleum Gas or LPG has become a very common fuel for internal combustion lift trucks.

**Following are precautions to be taken before refueling:**

- \_ Park the truck in the designated refueling area before refueling.
- \_ Place the directional control in neutral and engage the parking brake.
- \_ Lower the forks to the ground and angle the tips down.
- \_ Leave the engine running.
- \_ Close the service valve mounted on the LP bottle.



- \_ Allow the truck to run until the engine is out of fuel and quits.
- \_ Turn the key switch off.
- \_ Try to restart your truck.
- \_ If the truck starts and runs, all the fuel has not cleared out of the lines.

**You must wear protective clothing before changing an LP bottle, including: long sleeves, gauntlet gloves and eye protection.**

After all fuel is cleared from the lines and the truck fails to restart, uncouple the hose from the service valve, unlatch the restraint bracket that holds the bottle in place on the truck, and remove the bottle.

LP gas bottles must be stored in an approved outside area with the service valve in the "off" position. Reverse the procedure with a full bottle and reinstall it onto the truck.

Check the new bottle for any damage like dents or nicks and make sure the service valve is in the "off" position. Position the LP bottle over the locator pin and relatch the restraint brackets.

After reattaching the LP hose to the service valve, slowly open the valve. Do not open the valve too quickly. This will cause the back pressure relief valve to shut off the fuel supply. If this occurs, close the service valve for 5 seconds and then slowly reopen the valve. As the valve is being opened pay attention for the smell of LP gas. Immediately reclose the valve if you smell any gas, and remove the bottle. Mark or tag the faulty bottle and replace it with another good bottle.

Contact a supervisor if the problem occurs again and do not use the truck until the problem has been corrected. For any specific questions about equipment or refueling procedures, consult your supervisor.



# Certification Classes 1

## Topic 6 of 7: Fueling

### QUIZ

**1. Should you turn your gasoline or diesel lift truck off before refueling?**

- a) Yes
- b) No

**2. Is it OK to run out of fuel on an LP truck?**

- a) Yes
- b) No



# Certification Classes 1

## Topic 6 of 7: Fueling

### QUIZ ANSWER KEY

1. Should you turn your gasoline or diesel lift truck off before refueling?

- a) Yes
- b) No

2. Is it OK to run out of fuel on an LP truck?

- a) Yes
- b) No



**ForkliftCertification.com**  
**Certification Class 1**  
**Topic 7/7: Batteries**



## Topic 7/7: Batteries

In an electric powered lift truck the battery is the source of power for that vehicle. The routine for changing a battery in an electric powered truck is very different from the routine for refueling an internal combustion engine truck. Find out what your company's practices and safety rules are regarding battery charging and replacement. **Be sure you receive the proper instruction and authorization before you exchange, charge or service industrial batteries.**

Industrial batteries come in many different sizes. Electric trucks use different batteries and voltage configurations to achieve desired lifting capacities. In North America the main voltage configurations used are 12, 24, 36 and 48 volts. Check the truck's data plate for the correct battery specifications for your truck. Be sure you're using the correct battery and voltage configuration.

Before any battery maintenance is performed, you need put on the appropriate protective equipment. This gear consists of eye or face protection, rubber gloves, long sleeves and an apron. Consult your supervisor about your company's policy.

Battery acid is highly corrosive and can cause severe burns to the eyes and skin. If you come in contact with acid, go immediately to the nearest wash station and run water over the area for at least 15 minutes. Then seek medical attention.

When it becomes necessary to remove a battery make sure you use the proper equipment. Place the battery connector on top of the battery that needs to be moved. Lift truck batteries often weigh thousands of pounds and can cause serious injuries if handled improperly. Before moving the battery, make sure it is properly secured and positioned. Use caution when closing the battery cover.

Part of battery maintenance is charging. Charging should take place after the battery has been depleted.

Park the lift truck in the designated charging area. This well ventilated area should be free from sparks and high heat sources.



The top of the battery must not come in contact with any metal objects or electrical shorts can occur. Remove any jewelry, watches, or rings as a precaution.

Place the directional control in neutral and engage the parking brake. Lower the forks to the ground and angle the tips down. Turn the key switch to the "off" position. Open the battery compartment fully and allow hydrogen gas to vent off and heat buildup to subside. Check the battery charger and make sure it is set in the "off" position. Disconnect the battery connector from the truck and attach it to the connector on the battery charger. **Never** plug the connector on the battery charger into the connector mounted on the truck. This can severely damage the lift truck. Inspect the cables and connector on the battery for any damage. If there is no damage, turn on the charger and follow the manufacturer's charging instructions.



After the battery has finished charging, turn off the charger before unplugging the battery. Lift truck batteries have 3 eight-hour cycles in a day. They are:

1. The work cycle. The time when the battery in the lift truck is discharged to operate the truck.
2. The charge cycle. The time when the battery is connected to a battery charger for recharging.
3. The cool down cycle. The time after the charge cycle when gives the chemicals inside the battery cool down and stabilize. After this cycle has been completed the lift truck can be used again.

Quick charges are ineffective and shorten the life of the battery. A battery should discharge 80% of its capacity before being recharged. Any water that needs to be added to a battery, should be done after the battery has been recharged. The only exception to this is if the tops of the battery plates are exposed. Add just enough water to cover the top of the plates prior to recharging. Completely refilling the battery before recharging will boil out solution causing a hazardous spill. Any water that is added to the battery must be approved for industrial use.

Proper maintenance and care for industrial batteries is very important due to the cost of replacing them. A typical battery can cost can be in the around \$3,000. You may want to consult with your battery supplier for their recommendations on prolonging the life of batteries.

Always use the proper equipment for removal & reinstallation of batteries.





## Site Specifics

A site-specific evaluation is a thorough check of the specific work site conditions and hazards that apply to lift truck operation. Site-specific factors vary from one location to another and one operation to another. Each evaluation involves the judgement of the employer or supervisor working with the lift truck operator. The following are guidelines to help shape specific questions about any location or operation.

- \_ What are the company policies and rules for this location or operation?
- \_ What kinds of trucks are in use?
- \_ What types of surfaces will the lift trucks operate on?
- \_ Will lift trucks move from inside to outside?
- \_ Will operators have to leave their trucks to move inside or outside?
- \_ Are there visual obstructions to deal with?
- \_ Are there overhead obstructions to deal with?
- \_ Are there narrow isles or high traffic areas?
- \_ Is there a loading dock?
- \_ Is there any damage to buildings indicating a previous lift truck accident?
- \_ Are specialty trucks being used?
- \_ Where are fire and safety equipment located?
- \_ What special hazards are on the job site?



# Certification Classes 1

## Topic 7/7: Batteries

### QUIZ

**1. Is it important to wear eye or face protection when replacing a discharged battery in a lift truck?**

- a) Yes
- b) No

**2. Is it OK to quick charge a battery to finish a short job?**

- a) Yes
- b) No



# Certification Classes 1

## Topic 7/7: Batteries

### QUIZ ANSWER KEY

1. Is it important to wear eye or face protection when replacing a discharged battery in a lift truck?

- a) Yes
- b) No

2. Is it OK to quick charge a battery to finish a short job?

- a) Yes
- b) No

